

Features

- 1-channel isolated barrier
- 24 V DC supply (Power Rail)
- HART field device input with transmitter power supply
- Usable as signal splitter (1 input and several outputs)
- 2 relay contact outputs (change-over contacts)
- 3 analog outputs 4 mA ... 20 mA
- Sink and source mode output
- Configurable by keypad

Function

This isolated barrier is used for intrinsic safety applications. It is a HART loop converter that provides power to transmitters or can be connected to existing HART loops in parallel.

It is able to evaluate up to four HART variables (PV, SV, TV, QV). Of those four HART variables, the data contained in any three of them can be converted to three different 4 mA ... 20 mA current signals. These loop signals can be connected to display devices or analog inputs on the process control system/control system.

In addition to the current outputs, two form C changeover relay contacts are available and can be programmed to operate at trip values from the HART variables.

The unit is easily programmed by the use of a keypad located on the front of the unit or with the **PACTware™** configuration software.

For additional information, refer to the manual and

Assembly

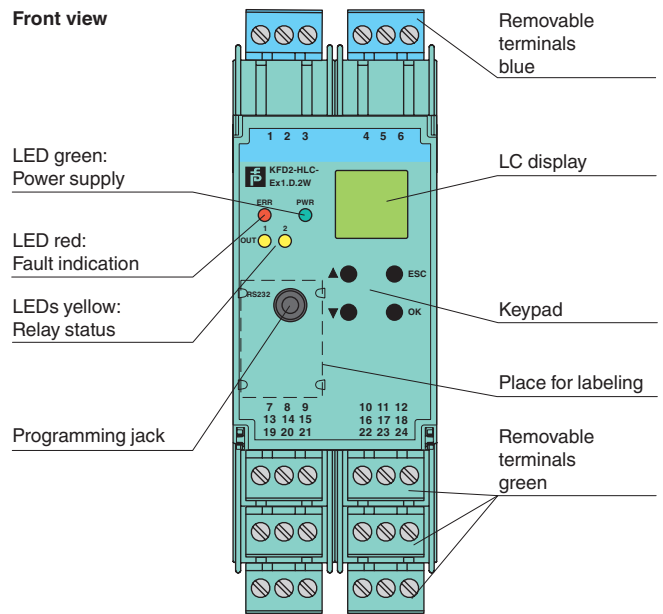

Application

- Configurable as primary or secondary master
- Automatic HART burst supported
- Support for a HART handheld device connected on safe area side
- Can be configured to assign the same input variable to multiple outputs (signal splitting)



Connection

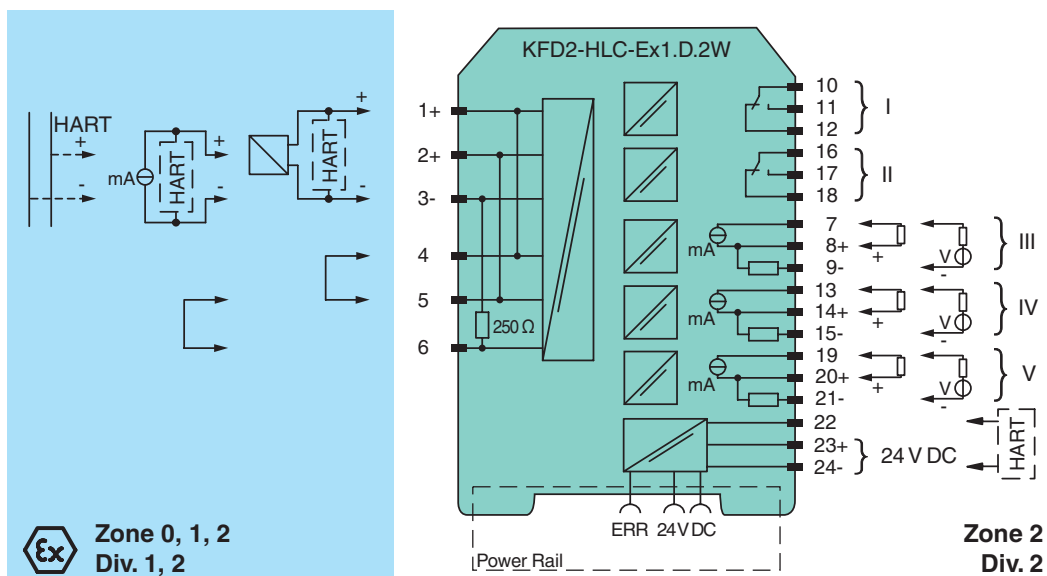

Release date 2018-07-30 09:42 Date of issue 2018-07-30 261918_eng.xml

General specifications		
Signal type		Analog input
Supply		
Connection		Power Rail or terminals 23+, 24-
Rated voltage	U_r	19 ... 30 V DC
Rated current	I_r	approx. 130 mA at 24 V DC
Power dissipation		2.5 W
Power consumption		3.1 W
HART signal channels (intrinsically safe)		
Conformity		HART field device input (revision 5 to 7)
Interface		
Programming interface		programming socket
Input		
Connection side		field side
Connection		terminals 1, 2, 3, 4, 5, 6
Open circuit voltage/short-circuit current		typ. 24 V / 28 mA
Input resistance		250 Ω , 5 % (terminals 2, 3 and with jumper on 5, 6)
Available voltage		≥ 15.5 V at 20 mA, short-circuit protected
Output		
Connection side		control side
Connection		output I: terminals 10, 11, 12, output II: terminals 16, 17, 18 output III: terminals 7, 8, 9, output IV: terminals 13, 14, 15, output V: terminals 19, 20, 21
Output I, II		
Output signal		relay and LED yellow
Mechanical life		10 ⁷ switching cycles
Energized/De-energized delay		approx. 20 ms / approx. 20 ms
Output III, IV, V		
Output signal		analog
Current range		4 ... 20 mA , (source or sink mode)
Load		$\leq 650 \Omega$, source mode
Voltage range		5 ... 30 V , sink mode from external supply
Fault signal		downscale $I \leq 2$ mA, upscale $I \geq 21.5$ mA (acc. NAMUR NE43) or hold measurement value
Other outputs		HART communicator on terminals 22, 24
Collective error message		Power Rail and LED red
Transfer characteristics		
Output III, IV, V		
Resolution		$\leq 2 \mu\text{A}$
Accuracy		$< 20 \mu\text{A}$, $10 \mu\text{A}$ typ.
Influence of ambient temperature		$< \pm 2 \mu\text{A/K}$
Duration of measurement/Response delay		HART message acquisition time plus 100 ms
Relay		programmable either for fault or trip value (with direction, hysteresis and delay)
Galvanic isolation		
Output I/II		functional insulation acc. to IEC 62103, rated insulation voltage 250 V_{eff}
Output I, II/other circuits		reinforced insulation acc. to IEC 62103, rated insulation voltage 300 V_{rms}
Output III/IV/V/power supply		functional insulation acc. to IEC 62103, rated insulation voltage 50 V_{eff}
Indicators/settings		
Display elements		LEDs , display
Control elements		Control panel
Configuration		via operating buttons via PACTware
Labeling		space for labeling at the front
Directive conformity		
Electromagnetic compatibility		
Directive 2014/30/EU		EN 61326-1:2013 (industrial locations)
Low voltage		
Directive 2014/35/EU		EN 61010-1:2010
Conformity		
Electromagnetic compatibility		NE 21:2006
Degree of protection		IEC 60529:2001
Ambient conditions		
Ambient temperature		-20 ... 60 °C (-4 ... 140 °F)
Mechanical specifications		
Degree of protection		IP20

Release date 2018-07-30 09:42 Date of issue 2018-07-30 261918_eng.xml

Connection		screw terminals
Mass		300 g
Dimensions		40 x 119 x 115 mm (1.6 x 4.7 x 4.5 inch) , housing type C3
Mounting		on 35 mm DIN mounting rail acc. to EN 60715:2001
Data for application in connection with hazardous areas		
EU-Type Examination Certificate		BASEEFA 07 ATEX 0174
Marking		⊕ II (1)G [Ex ia Ga] IIC ⊕ II (1)D [Ex ia Da] IIIC
Supply		
Maximum safe voltage	U_m	253 V AC (Attention! The rated voltage can be lower.)
Equipment		terminals 1, 4/3 (with link between terminals 4 and 5)
Voltage	U_o	25.2 V
Current	I_o	104.9 mA
Power	P_o	0.661 W
Equipment		terminals 2, 5/3
Voltage	U_i	< 28 V
Power	P_i	< 1.33 W
Voltage	U_o	1.1 V
Current	I_o	11.9 mA
Power	P_o	4 mW
Output I, II		terminals 10, 11, 12; 16, 17, 18 , non-intrinsically safe
Maximum safe voltage	U_m	253 V (Attention! U_m is no rated voltage.)
Contact loading		253 V AC/1 A/cos $\phi > 0.7$; 30 V DC/1 A resistive load (BASEEFA 07 ATEX 0174) 50 V AC/1 A/cos $\phi > 0.7$; 30 V DC/1 A resistive load (Pepperl+Fuchs self-declaration)
Output III, IV, V		terminals 7, 8, 9; 13, 14, 15; 19, 20, 21 , non-intrinsically safe
Maximum safe voltage	U_m	253 V (Attention! U_m is no rated voltage.)
Certificate		PF 07 CERT 1141 X
Marking		⊕ II 3G Ex nA nC IIC T4 Gc
Galvanic isolation		
Input/Other circuits		safe electrical isolation acc. to IEC/EN 60079-11, voltage peak value 375 V
Directive conformity		
Directive 2014/34/EU		EN 60079-0:2012+A11:2013 , EN 60079-11:2012 , EN 60079-15:2010
International approvals		
FM approval		
Control drawing		116-0129
IECEX approval		
IECEX certificate		IECEX BAS 07.0047
IECEX marking		[Ex ia Ga] IIC , [Ex ia Da] IIIC
General information		
Supplementary information		Observe the certificates, declarations of conformity, instruction manuals, and manuals where applicable. For information see
Accessories		
Optional accessories		- power feed module KFD2-EB2(.R4A.B)(.SP) - universal power rail UPR-03(-M)(-S) - profile rail K-DUCT-BU(-UPR-03)